

EXTRA SET OF MANDRELS FOR LARGE RINGS

GRS

PART #004-616

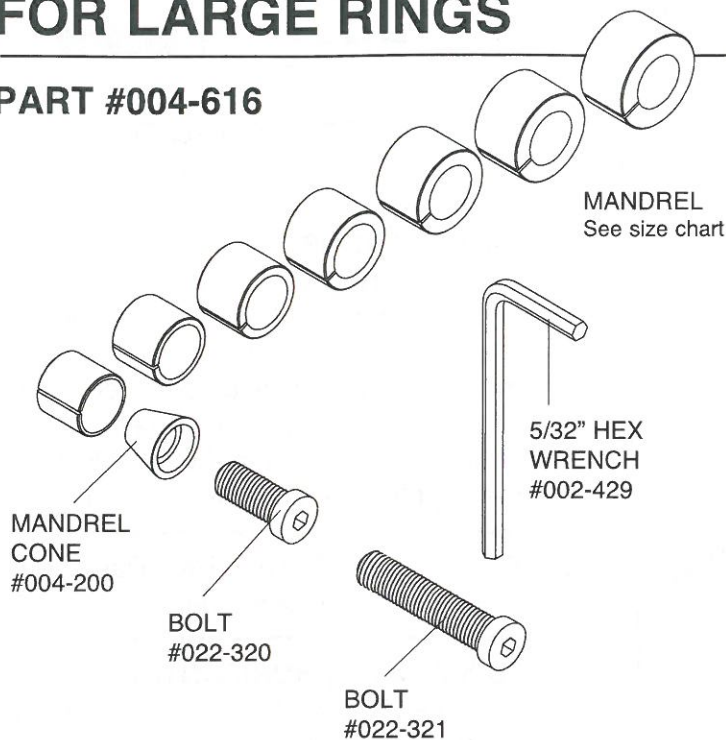

MANDREL

Select the mandrel which is slightly smaller than the inside ring diameter.

- 004-170 .575"
- 004-171 .625"
- 004-172 .675"
- 004-173 .725"
- 004-174 .775"
- 004-216 .825"
- 004-217 .875"

NOTE: Mandrel CONE Taper fits into Mandrel Taper

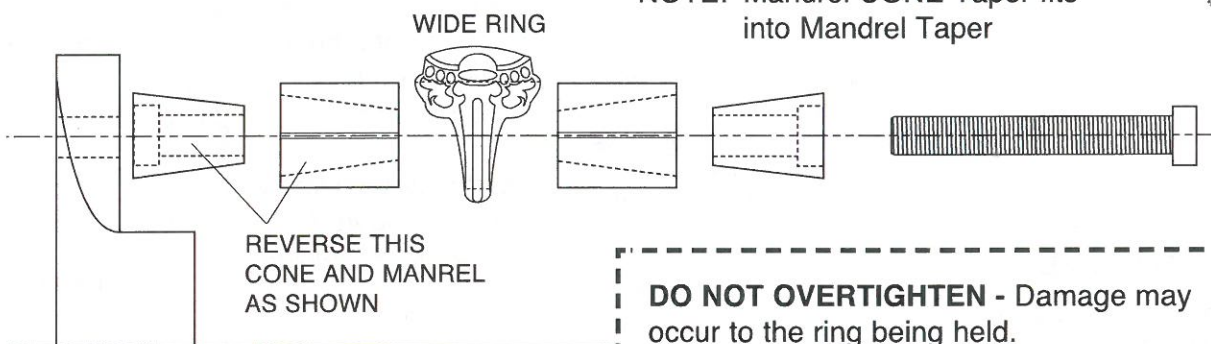

INSTRUCTIONS:

To hold a ring VERTICAL

To hold large / wide rings use TWO of the SAME SIZE mandrels and TWO mandrel cones. Insert the long bolt through the first mandrel cone and place cone into the tapered end of the mandrel you have selected. Then reverse the second mandrel and place on bolt. Slide the second cone into that mandrel so that the taper angles match. (See Illustration above) Position ring on the selected mandrel. Tighten the socket head screw into the Ring Post with the supplied wrench until the ring is snug.

To hold a ring HORIZONTAL

Turn the Ring Post upside down and use the threaded hole on the bottom to secure the mandrel and cone assembly. Switch the Stop Pin to the side hole that is closest to the work for use in a BenchMate®.

*SEE OTHER SIDE FOR
MORE INFORMATION*