

DH1~DH2=16171 (±20)

Coordinates			
Mark	X	Y	R
GM	0	0	—
h1	7270	4825	350
h2	-7270	4825	350
h3	-7270	-4825	350
h4	7587	-4025	325
DH1	-7900	-3000	—
DH2	8284	-1900	—
a1	2793	7550	500
a2	6600	5539	300
a3	7200	4787	300
a4	8299	3350	300
a5	8900	1632	300
a6	8900	-1632	300
a7	8299	-3350	300
a8	7200	-4787	300
a9	6600	-5539	300
a10	2793	-7550	500
a11	-2793	-7550	500
a12	-6600	-5539	300
a13	-7200	-4787	300
a14	-8299	-3350	300
a15	-8900	-1632	300
a16	-8900	1632	300 </td
a17	-8299	3350	300
a18	-7200	4787	300
a19	-6600	5539	300
a20	-2793	7550	500
f21	5788	7505	1500
f22	5788	-7505	1500
f23	-5788	-7505	1500
f24	-6864	6800	1500

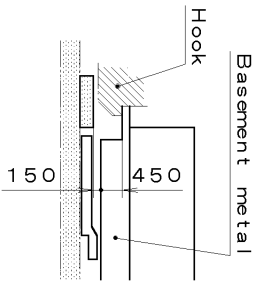

Section f21~f24

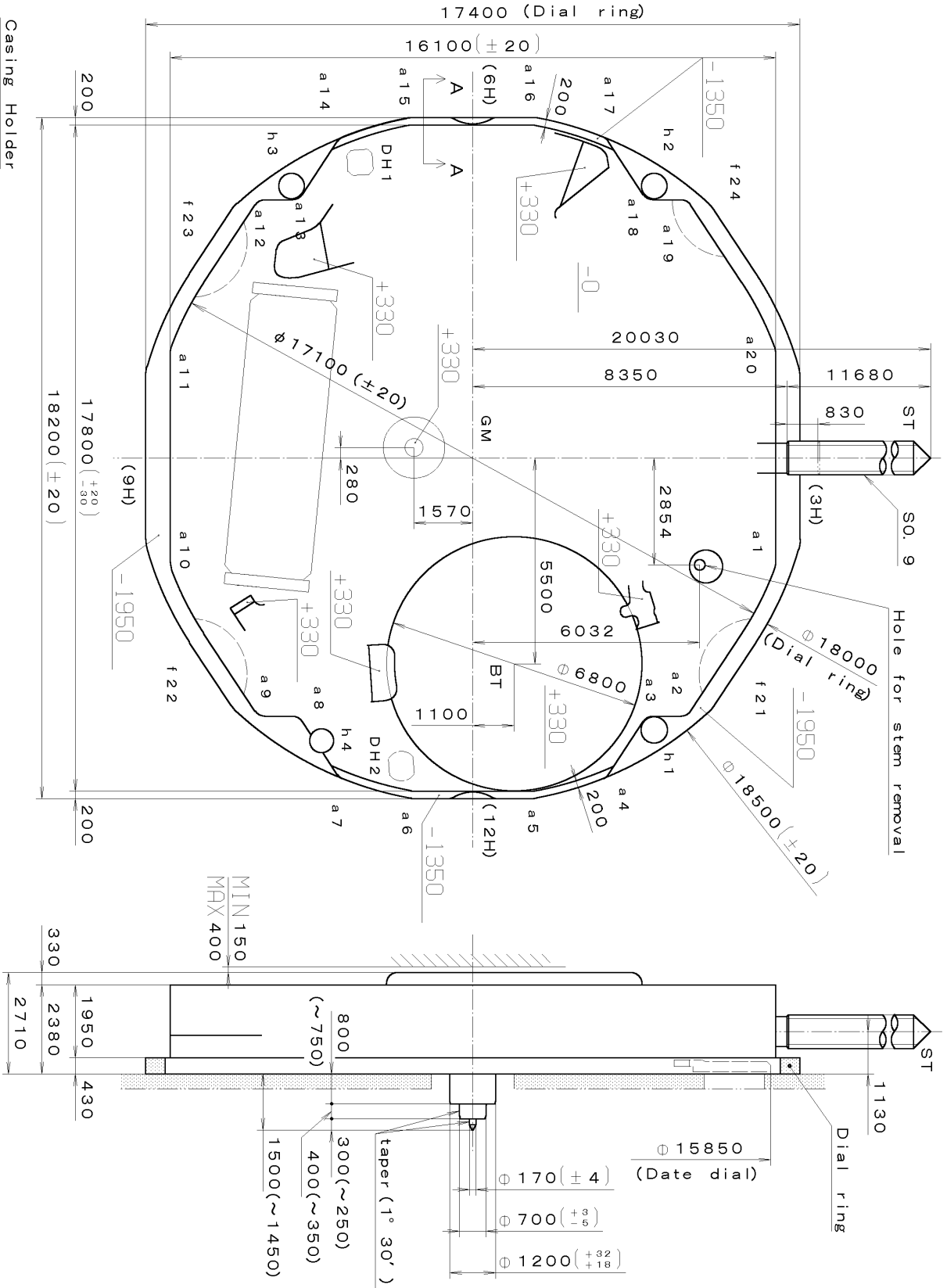
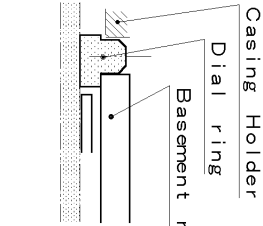

Section h1~h4

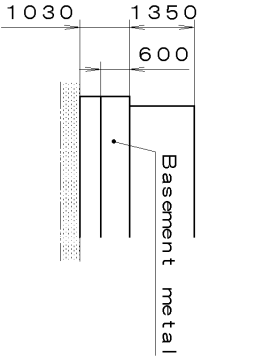

Section A-A

△		Quantity		Cal. No. :	1L12
△		Unit	1/1000 mm	Parts:	
△		Scale	9:1	Name:	Frame for Case
△		Date		Checked	T. Hiruta
△		Drawn		Approved	
△		Material		Drawing No. :	1L12C0000
		Heat Treatment		CITIZEN WATCH CO., LTD.	
		Hardness		TOKYO, JAPAN	
		Plating			
General Tolerances					
Dimensions					
Angles					

This drawing is provisional and subject to our reconfirmation and/or revision without notice.

\*\*\* T I P W (01) \*\*\* (2100 1121) 00-06-14

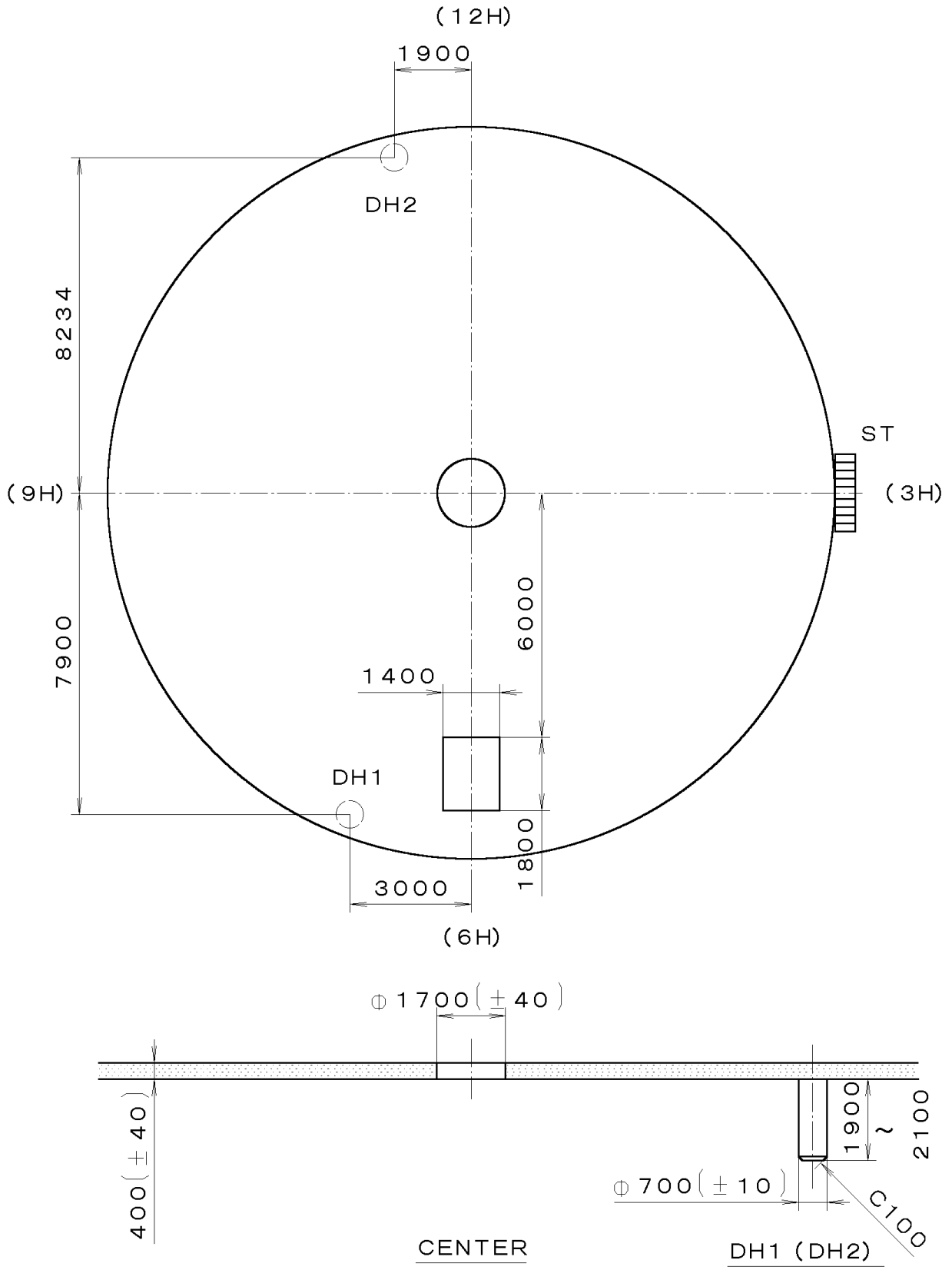

7		Quantity		Cal. No. :	1L12-10Z
6		Unit	1/1000 mm	Parts:	
5		Scale	7:1	Name:	Indications for Dial
4		Date		Drawing No. :	1L12D000
3		Drawn			
2		Checked	T. Hiruta		
1		Approved			
Material					
Heat Treatment		General Tolerances		<b>CITIZEN</b> WATCH CO.,LTD. TOKYO, JAPAN	
Hardness		Dimensions			
Plating		Angles			

This drawing is provisional and subject to our reconfirmation and/or revision without notice.

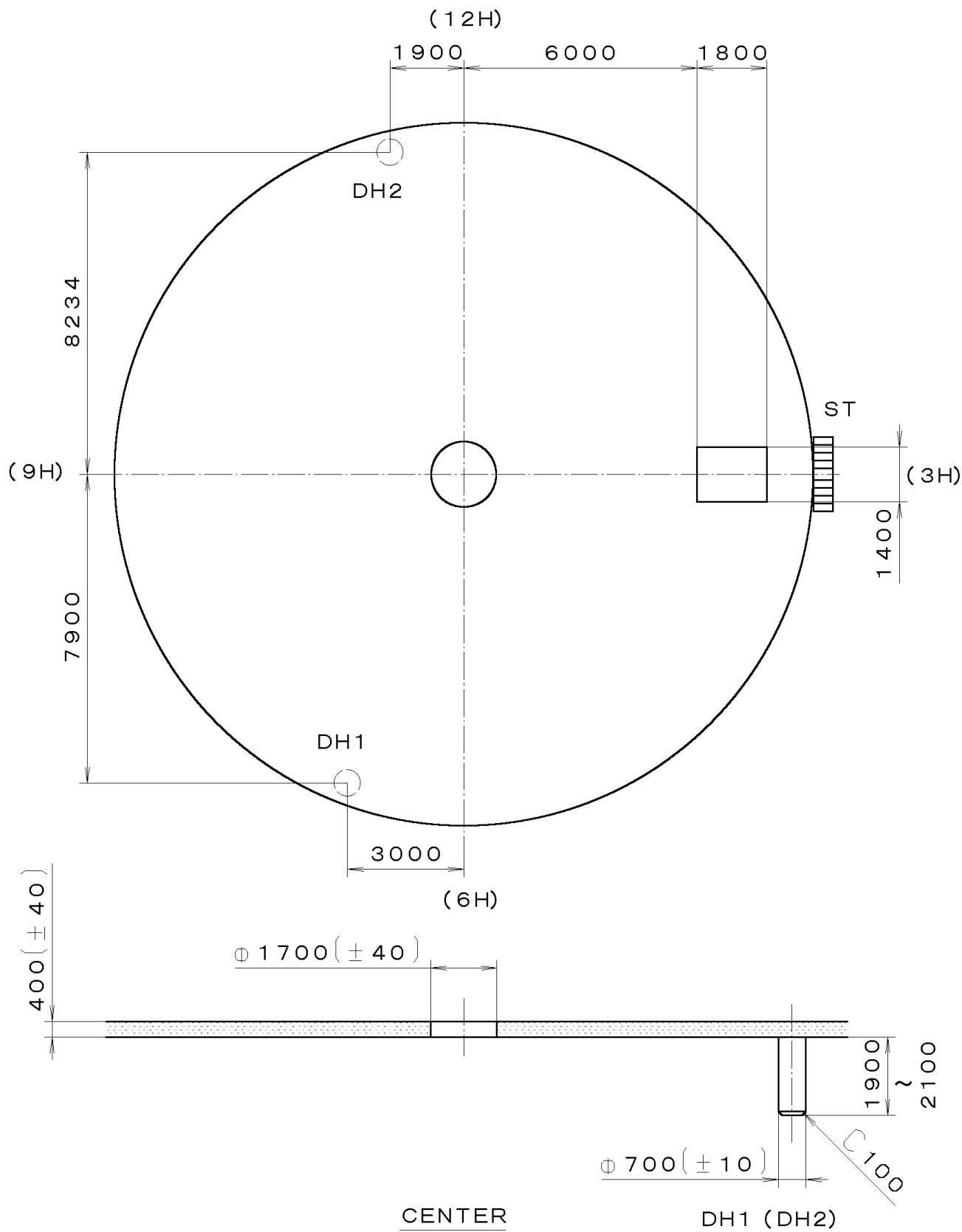

\*\*\* T I P W (01) \*\*\* (2100 1121) 00-06-16

7		Quantity		Cal. No. :	1L12-10A
6		Unit	1/1000 mm	Parts:	
5		Scale	7:1	Name:	Indications for Dial
4		Date		Drawing No. :	1L12D010
3		Drawn			
2		Checked	T. Hiruta		
1		Approved			
Material					
Heat Treatment		General Tolerances		<b>CITIZEN</b> WATCH CO., LTD. TOKYO, JAPAN	
Hardness		Dimensions			
Plating		Angles			

This drawing is provisional and subject to our reconfirmation and/or revision without notice.

\*\*\* T I P W (01) \*\*\* (2100 1121) 00-07-06 30.0

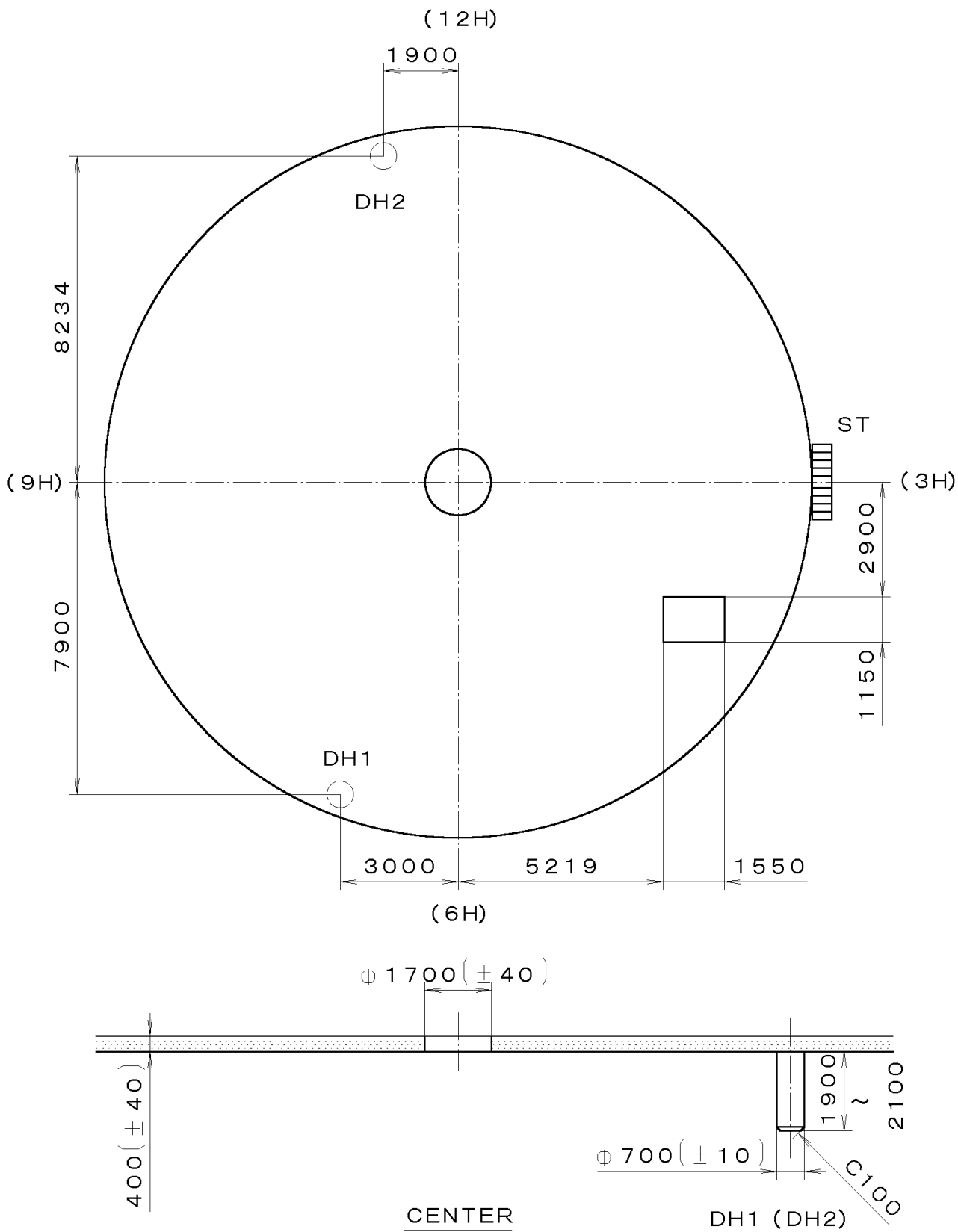

7			Quantity		Cal. No. :	1L12-10X
6			Unit	1/1000 mm	Parts:	
5			Scale	7:1	Name:	Indications for Dial Drawing No. : 1L12D020
4			Date			
3			Drawn			
2			Checked	T. Hiruta		
1			Approved			
Material						
Heat Treatment			General Tolerances			
Hardness			Dimensions			
Plating			Angles			

**CITIZEN** WATCH CO., LTD.  
TOKYO, JAPAN

This drawing is provisional and subject to our reconfirmation and/or revision without notice.

065-505 (01) \*\*\* (2100 1121 A-01 A-01 ) 00-06-22

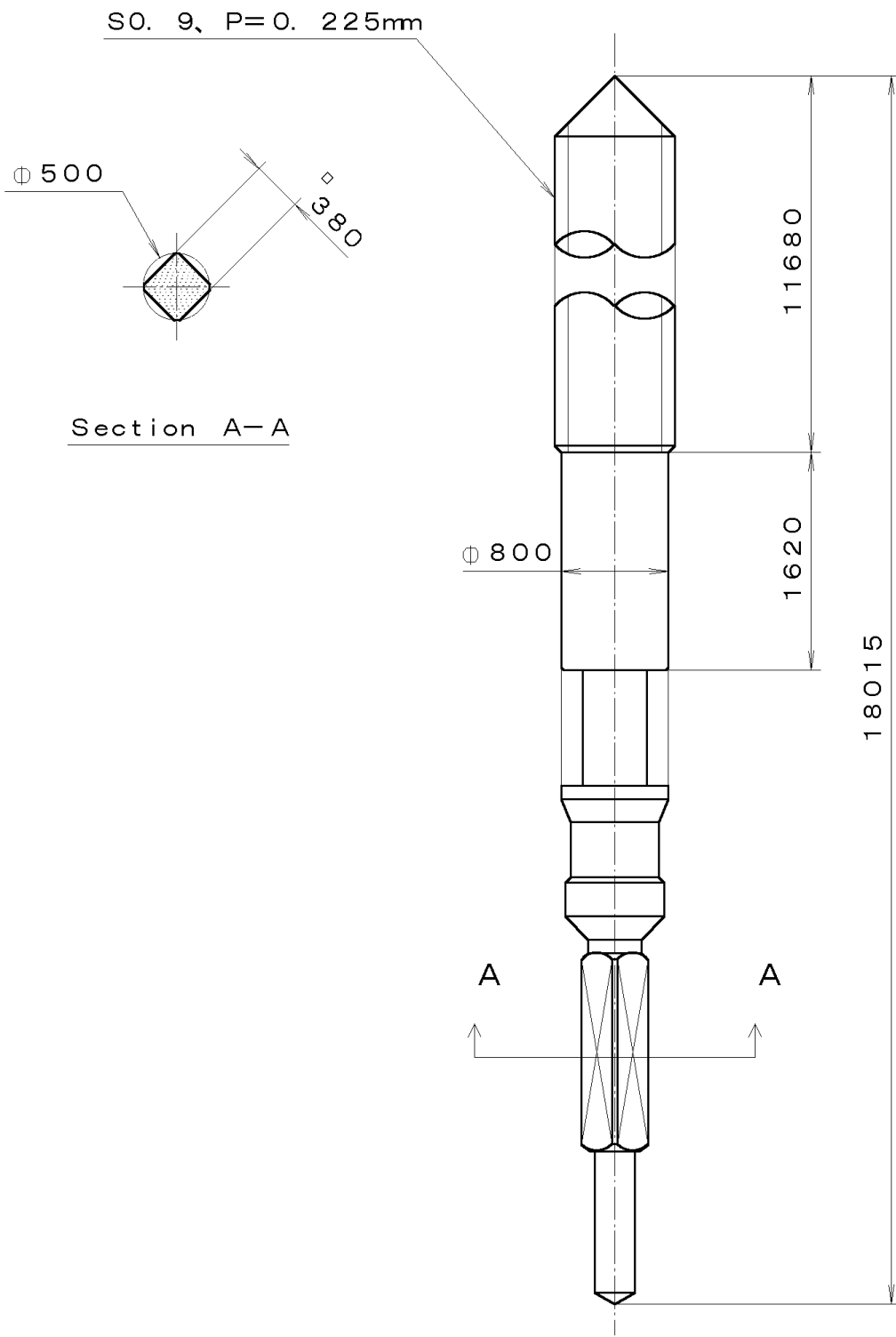

7			Quantity		Cal. No. :
6			Unit	1/1000 mm	
5			Scale	20:1	Parts:
4			Date		065-505
3			Drawn		Name:
2			Checked	T. Hiruta	SETTING STEM
1			Approved		Drawing No. : 5050S000
Material					
Heat Treatment			General Tolerances		
Hardness			Dimensions		
Plating			Angles		

**CITIZEN** WATCH CO., LTD.  
TOKYO, JAPAN